

Joshua Wurman  
University of Oklahoma

Mitch Randall  
National Center for Atmospheric Research

### 1. The need for rapid scanning

Many phenomena are difficult or impossible to characterize with existing slowly scanning radars, mobile or stationary. The limitations of traditional radars have long been recognized (Keeler and Frush, 1983) with respect to radar observations of severe weather and phenomena threatening to aviation such as microbursts. Storm evolution during radar scans can cause significant retrieval errors (Clark et al., 1980).

Tornadoes, microbursts, dust-devils, hurricane boundary layer wind streaks, etc. evolve on time and space scales too short to be well observed with conventional radars. Data from the DOWs suggest that phenomena associated with tornadogenesis evolve on timescales that are unobservable with conventional scanning radars. Wind streaks in the hurricane BL evolve and translate quickly, requiring observations at least as frequently as 10 s.

**Tornadoes:** The Doppler On Wheels (DOW) radars have been used since 1995 to study a variety of atmospheric phenomena. Unfortunately, the time required for complete volumetric sector scans was typically 40-60 s. During that period, radical structural changes occurred in at least two observed tornadoes. Thus it was impossible to study the evolution from one structural state to another. The DOWs observed several tornadoes, some with volume updates as low as 30 s, sometimes

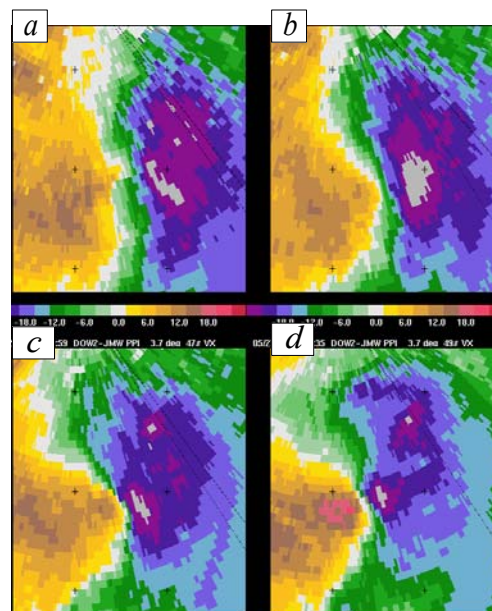

Figure 1. Doppler velocity signature during the genesis of a weak tornado on 26 May 1997. Significant changes occur in the windfield structure between each of the frames. Frames are separated by 28 s. Plot area is 3 x 3 km.

repeating slices through particular altitudes at intervals as short as 13 s. These data showed that, particularly at the time of genesis, important structural changes can occur in < 30 s (Fig 1).

**Hurricanes:** During DOW intercepts of landfalling hurricanes, intense quasi-periodic boundary layer wind streaks were observed (Wurman and Winslow, 1998) and hypothesized to be the result of flow parallel boundary layer rolls. The streaks exhibited transverse scales of 100-600 m, and along-roll variation at scales of 500-1000 m. In an ambient flow of  $40 \text{ ms}^{-1}$ , with  $\pm 20 \text{ ms}^{-1}$  perturbations associated with the rolls, the

---

Corresponding author address: Joshua Wurman, School of Meteorology, University of Oklahoma, 100 E. Boyd Street, Norman, OK 73019, [jwurman@ou.edu](mailto:jwurman@ou.edu)

evolution time scales of the most intense and small scale perturbations might be 5-10 s. These radar data revealed the 2D representation of gustiness at the 5 s time scale that might be partially responsible for small scale variability in surface damage patterns (Wakimoto and Black 1994, Powell and Houston 1996). Data from hurricane Georges and Bonnie, and an intense cold front confirm the presence of these structures. To resolve these time scales, a rapid-scan radar is required.

Conventional phased array rapid-scan technologies are prohibitively expensive. Rapid evolution and small-scales are tightly linked, therefore **rapid-scan and mobility go hand in hand**. Stationary rapid scan radars are of limited added utility beyond the several km range of ultrahigh resolution observations. Beyond this, only larger-scale slowly evolving systems are resolvable.

## 2. The Rapid-DOW

We have begun the development of an experimental rapid-DOW using hybrid electronic/mechanical scanning with a multiple beam system to collect partial volumetric data in ~10 s.

The Rapid-DOW will incorporate a slotted waveguide array antenna (Fig 2) specifically

*Figure 2. The Rapid-DOW employs a slotted waveguide array to produce several 0.9-1.0° pencil beam. The waveguides will be fed by a sinuous feed oriented vertically.*

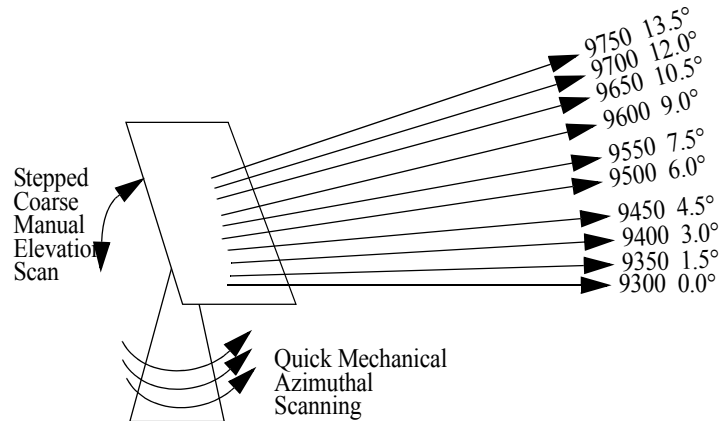
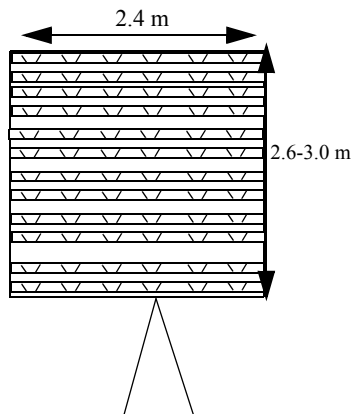

*Figure 3. Illustration of beam dispersion from nearly simultaneously transmitted beams and simultaneously received beams. Antenna is quickly scanned manually in azimuth and stepped through a coarse elevation pattern.*

designed to produce frequency dependent beam steering. Energy from a single transmitter, producing 6-10 different frequencies nearly simultaneously, will be emitted in 6-10 pencil-beams, each with a different elevation angle (Fig 3). Fast mechanical azimuthal scanning will result in a 6-10-beam sweep of the sky in six seconds. A single elevation stagger would permit an additional 6-10 elevation angles to be collected in the next six seconds, resulting in a 12-20 tilt volume scan in 12 seconds. (i.e. sweep #1 will transmit at 1°-15° during the 0-6 second time period, then the antenna will be inclined by 15° to collect data from 16°-30°, during the 6-12 second time period, etc.)

The antenna array, approximately 2.4 m on a side, will consist of 30-60 individual slotted waveguide elements. At any given frequency, the array will produce a 0.9°-1.0° beam. All returned signals pass through single rotary joints, circulator, and amplifier and initial IF downconversion, before being split and sent to individual frequency modules (channels). (Figs. 3,4). Steering will be approximately .03° (MHz)<sup>-1</sup>, producing approximately 15° steering across the X-band spectrum (9.3-9.8 GHz). Pulse lengths as short as 125 ns, will

result in negligible dispersion (8MHz effective bandwidth results in just .24° dispersion) within individual beams. Minimum frequency separations can be adjusted depending on pulselengths in order to provide channel isolation.

Returned energy from all of the beam will be received simultaneously, then split and processed by individual frequency modules (Fig. 4). The frequency of each individual beam will be independently controlled by individual synthesizers in each frequency module (Fig 5). By changing the frequencies of the transmitted energy, the elevation angle offsets of the individual beams can be modified. Thus, elevation angle offset sets can be tailored for boundary layer or deep convective studies.

The elevation angle of any beam can be changed on a integration-time-by-integration-time basis, permitting saw-toothed or dithered scans. This would permit a better matching of horizontal and vertical observation scales.

NCAR's new PIRAQ-3 processors will compute Doppler and other products from two channels (frequencies) each.

Figure 4. Simplified block diagram illustrating several of the frequency modules and the processing module with PIRAQ-3s.

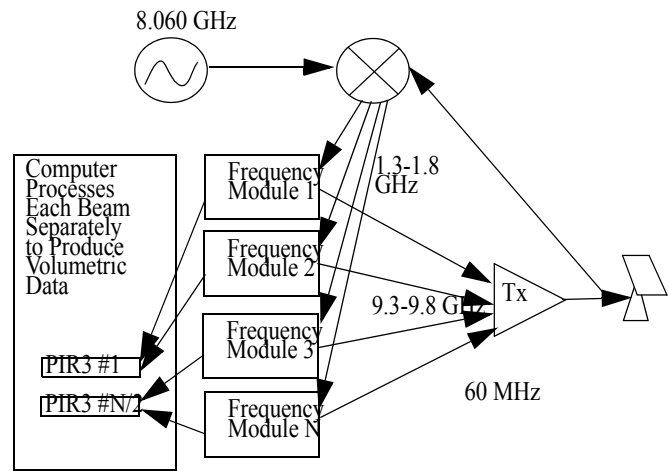

Figure 5. (below) More detailed schematic illustrating frequency generation, combining, and analog processing of received data from one beam.

